

# WEIDER® 130 TC

Model No. WEEVBE3909.0

Serial No. \_\_\_\_\_

Write the serial number in the space above for reference.

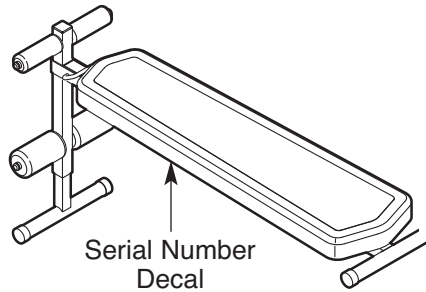

## USER'S MANUAL

### QUESTIONS?

If you have questions, or if there are missing parts, please contact us:

Call: 08457 089 009

From Ireland: 00 (44) 53 9236102

Website: [www.iconsupport.eu](http://www.iconsupport.eu)

E-mail: [csuk@iconeurope.com](mailto:csuk@iconeurope.com)

Write:

ICON Health & Fitness, Ltd.

c/o HI Group PLC

Express Way

Whitwood, West Yorkshire

WF10 5QJ

UK

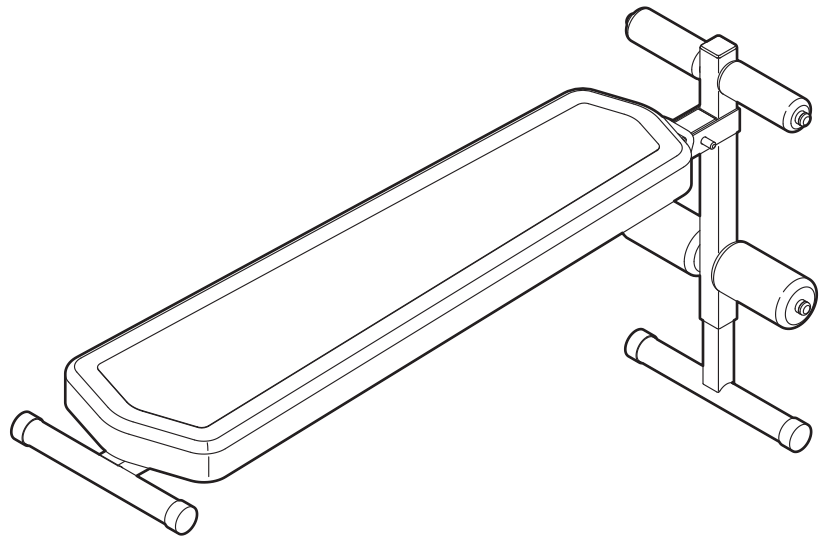

### ⚠ CAUTION

Read all precautions and instructions in this manual before using this equipment. Keep this manual for future reference.

[www.iconeurope.com](http://www.iconeurope.com)

# TABLE OF CONTENTS

WARNING DECAL PLACEMENT .....	.2
IMPORTANT PRECAUTIONS .....	.3
BEFORE YOU BEGIN .....	.3
ASSEMBLY .....	.4
ADJUSTMENT .....	.5
EXERCISE GUIDELINES .....	.6
PART LIST AND EXPLODED DRAWING .....	.7
ORDERING REPLACEMENT PARTS .....	.Back Cover

## WARNING DECAL PLACEMENT

This drawing shows the location(s) of the warning decal(s). **If a decal is missing or illegible, see the front cover of this manual and request a free replacement decal. Apply the decal in the location shown.** Note: The decal(s) may not be shown at actual size.



**⚠ WARNING**

User Weight: Max 250 LBS  
Weight Crutch: Max 110 LBS  
Leg Developer: Max 50 LBS  
Weight Carriage: Max 110 LBS  
Chest Fly Per Arm: Max 30 LBS

Product may not offer all listed exercises.

**⚠ WARNING**

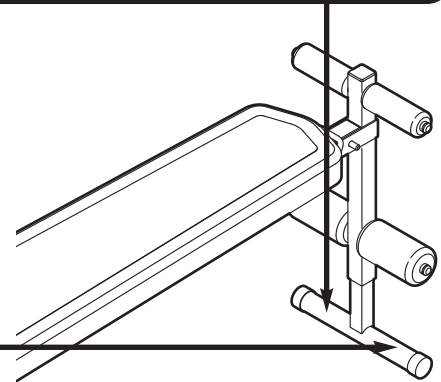
- Misuse of this machine may result in serious injury.
- Read user's manual prior to use and follow all warnings and instructions.
- Do not allow children on or around machine.
- Keep body, clothing, and hair free and clear of all moving parts.
- Replace label if damaged, illegible, or removed.



---

## IMPORTANT PRECAUTIONS

**⚠ WARNING:** To reduce the risk of serious injury, read all important precautions and instructions in this manual and all warnings on your bench before using your bench. ICON assumes no responsibility for personal injury or property damage sustained by or through the use of this product.

1. Before beginning any exercise program, consult your physician. This is especially important for persons over age 35 or persons with pre-existing health problems.
2. Read all instructions in this manual and all warnings on the bench before using the bench.
3. It is the responsibility of the owner to ensure that all users of the bench are adequately informed of all precautions.
4. The bench is intended for home use only. Do not use the bench in any commercial, rental, or institutional setting.
5. Keep the bench indoors, away from moisture and dust. Place the bench on a level surface, with a mat beneath it to protect the floor or carpet. Make sure that there is enough clearance around the bench to mount, dismount, and use the bench.
6. Keep children under age 12 and pets away from the bench at all times.
7. Inspect and properly tighten all parts regularly. Replace any worn parts immediately.
8. Keep hands and feet away from moving parts.
9. Always wear athletic shoes for foot protection.
10. The bench is designed to support a maximum user weight of 250 lbs. (113 kg). The bench is not designed to be used with weights.
11. If you feel pain or dizziness at any time whilst exercising, stop immediately and begin cooling down.

---

## BEFORE YOU BEGIN

Thank you for selecting the new WEIDER® 130 TC bench. The 130 TC bench is designed to help you develop your upper and lower abdominal muscles to give you a firm, flat stomach in only minutes a day.

**For your benefit, read this manual carefully before using the bench.** If you have questions after reading

this manual, please see the front cover of this manual. To help us assist you, note the product model number and serial number before contacting us. The model number and the location of the serial number decal are shown on the front cover of this manual.

# ASSEMBLY

Place all parts in a cleared area and remove the packing materials; do not dispose of the packing materials until assembly is completed.

Assembly requires your own Phillips screwdriver  and two adjustable wrenches .

1. **To make assembly easier, read the information above before you begin.**

Attach the Backrest (3) to the Frame (1) with four M6 x 16mm Screws (5).

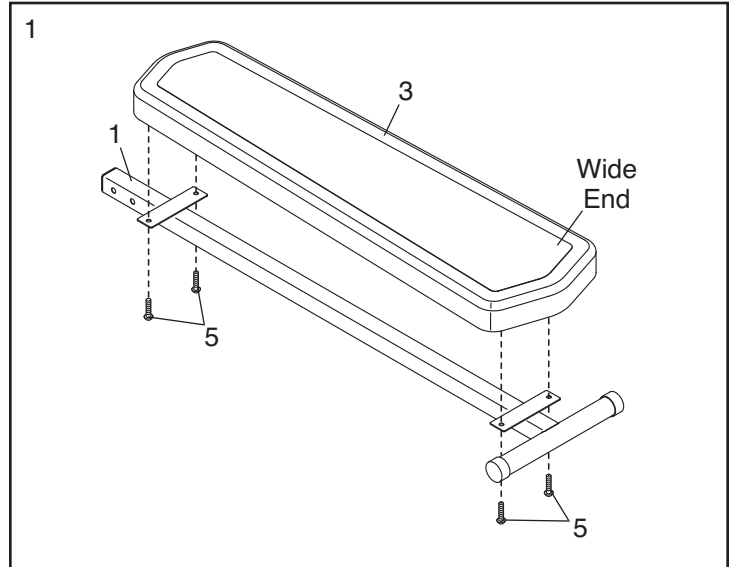

2. Attach the Leg (2) to the Frame (1) with an M10 x 57mm Bolt (12) and an M10 Locknut (13). **Do not overtighten the Locknut; the Leg must pivot freely.**

Insert the Adjustment Pin (14) into the Leg (2) and the Frame (1). **Rotate the Adjustment Pin so that the bent end is over the Frame.**

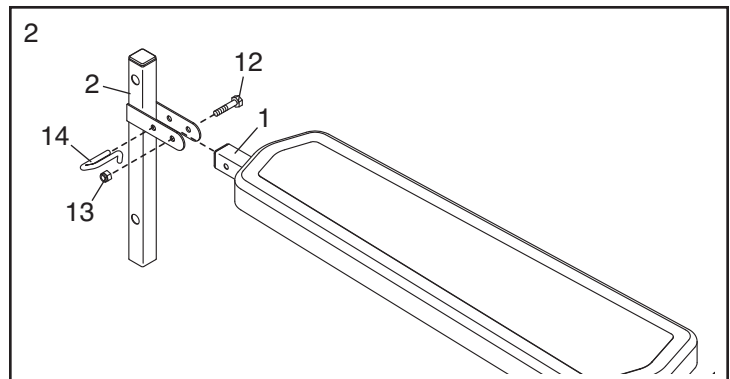

3. Insert a Pad Tube (4) into the upper hole in the Leg (2). Slide the two Small Foam Pads (6) onto the Pad Tube.

Insert the Adjustment Foot (8) into the Leg (2). **Make sure that the warning decals are in the indicated locations.**

Insert the remaining Pad Tube (4) into the lower hole in the Leg (2) and into one of the holes in the Adjustment Foot (8). Then, slide the two Large Foam Pads (7) onto the Pad Tube.

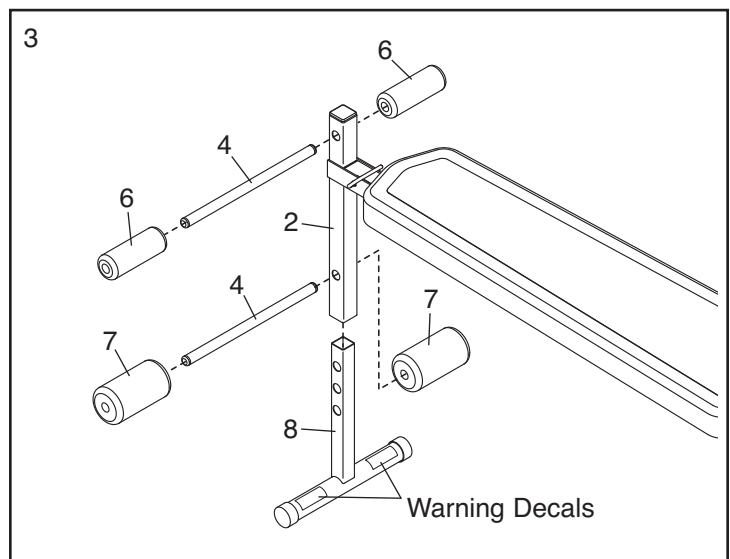

# ADJUSTMENT

Make sure that all parts are properly tightened each time the bench is used. Replace any worn parts immediately. The bench can be cleaned with a damp cloth and a mild, non-abrasive detergent; **do not use solvents.**

## HOW TO ADJUST THE BENCH

To adjust the angle of the bench, first remove one of the Large Foam Pads (7) from the lower Pad Tube (4).

Next, remove the Pad Tube (4) from the Leg (2).

**Adjust the Adjustment Foot (8) to the desired height, and then reinsert the Pad Tube (4) into the Leg (2) and the Adjustment Foot.**

Then, slide the Large Foam Pad (7) onto the Pad Tube (4).

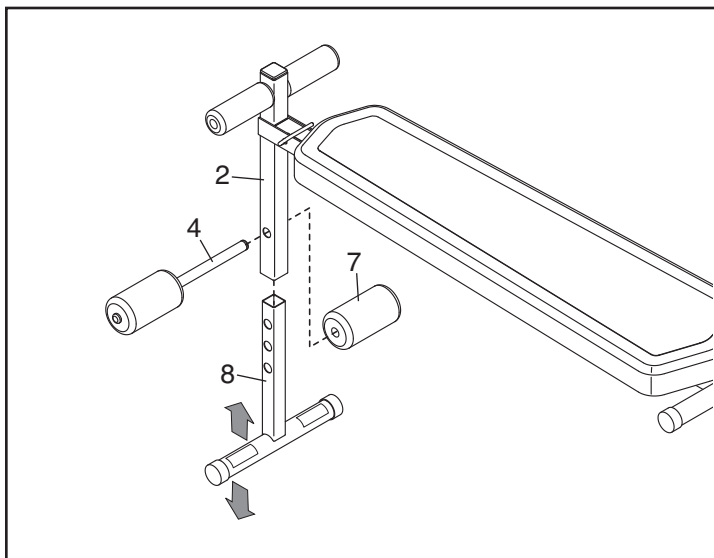

## HOW TO FOLD THE BENCH

To fold the bench, first remove the Adjustment Pin (14).

Next, fold the Leg (2) in the indicated direction.

**Before using the bench, make sure that the Adjustment Pin (14) is fully inserted into the Leg (2) and the Frame (1).**

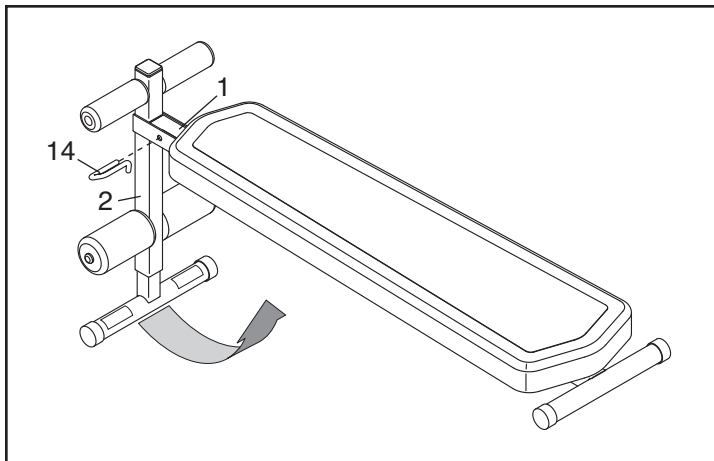

---

## EXERCISE GUIDELINES

The bench will help you shape your upper and lower abdominal muscles. Be careful not to overdo it during the first few weeks of your exercise program.

**⚠ WARNING:** Before beginning this or any exercise program, consult your physician. This is especially important for persons over age 35 or persons with pre-existing health problems.

To get the most from your exercise, proper form is important. As you perform each repetition, use your abdominal muscles to pull yourself upward, moving in a smooth continuous motion.

Always begin and end each workout with a few minutes of stretching. Remember to keep plenty of water nearby as you exercise, and drink periodically to avoid dehydration. **If you feel faint, dizzy, or short of breath at any time during exercise, stop immediately and begin cooling down.**

---

### LEG RAISES

Lie on the bench, grasp the small foam pads, and extend your legs as shown. Lift your legs with a slow, steady motion—avoid rapid or jerky movements. Return to the starting position. Repeat.

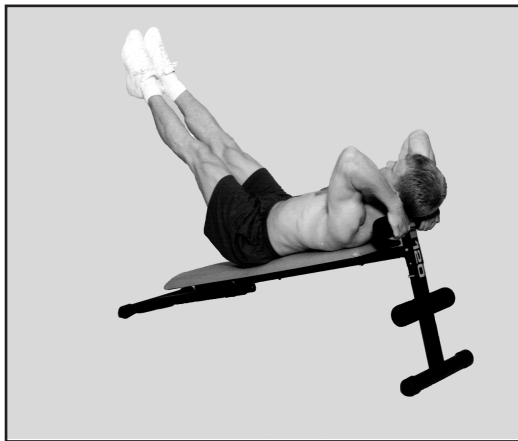
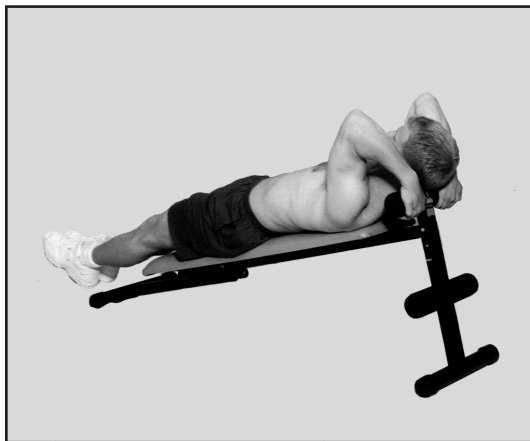

### CRUNCHES

Lie on the bench and tuck your feet under the large foam pads as shown. Bend forward at the waist, keeping your back straight, and sit up as shown. Return to the starting position. Repeat.



# PART LIST AND EXPLODED DRAWING

R0509A

## Model No. WEEVBE3909.0

Key No.	Qty.	Description	Key No.	Qty.	Description
1	1	Frame	9	4	38mm Round Outer Cap
2	1	Leg	10	2	38mm Square Inner Cap
3	1	Backrest	11	4	19mm Round Inner Cap
4	2	Pad Tube	12	1	M10 x 57mm Bolt
5	4	M6 x 16mm Screw	13	1	M10 Locknut
6	2	Small Foam Pad	14	1	Adjustment Pin
7	2	Large Foam Pad	*	-	User's Manual
8	1	Adjustment Foot			

Note: Specifications are subject to change without notice. For information about ordering replacement parts, see the back cover of this manual. \*These parts are not illustrated.

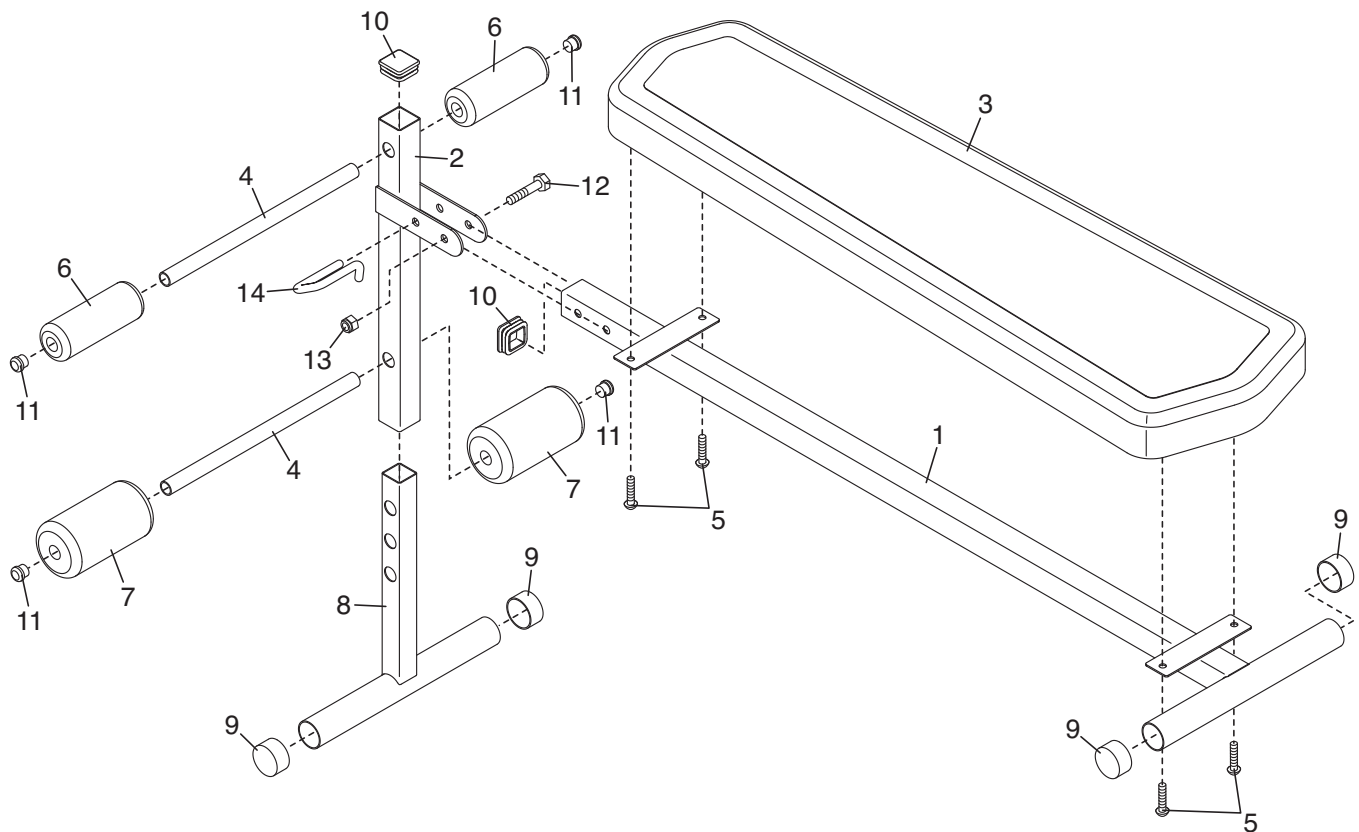

---

# ORDERING REPLACEMENT PARTS

To order replacement parts, please see the front cover of this manual. To help us assist you, be prepared to provide the following information when contacting us:

- the model number and serial number of the product (see the front cover of this manual)
- the name of the product (see the front cover of this manual)
- the key number and description of the replacement part(s) (see the PART LIST and the EXPLODED DRAWING near the end of this manual)